

Survey of Transistor Development

Parts I, II, and III

By

B. N. SLADE



Reprinted from RADIO & TELEVISION NEWS
September, October, November, 1952

Publication No. ST-680



TUBE DEPARTMENT
RADIO CORPORATION OF AMERICA
HARRISON NEW JERSEY

USE OF NEW LOW-NOISE TWIN TRIODE IN TELEVISION TUNERS*

BY
ROBERT M. COHEN

Tube Department, RCA Victor Division,
Harrison, N. J.

Summary—The sensitivity of television receivers can be substantially improved through the use of the 6BQ7, a new low-noise double triode, as a radio-frequency amplifier in "driven-grounded-grid" circuits devised specifically for this application. The merits of these circuits are discussed, with emphasis on the relationship between circuit performance and tube characteristics. Data are presented on noise figure, image rejection, gain, and standing-wave ratio for various frequencies in the very-high-frequency television bands. The attenuation of local-oscillator energy in the radio-frequency amplifier tube, an important factor in reducing total oscillator radiation, is greater with this tube and associated circuits than with comparable pentode circuits. The practical problems of applying the new circuits to a twelve-channel tuner are discussed. The use of the 6BQ7 in a low-noise intermediate-frequency preamplifier stage for ultra-high-frequency television receivers is also discussed, and pertinent data on noise figure, gain, and selectivity are provided.

INTRODUCTION

SEVERAL years ago the writer investigated the performance of various receiving tubes in the radio-frequency positions of very-high-frequency television receivers.¹ The need for improvement in tuner performance evidenced then has resulted in the development of a new double triode, the 6BQ7, and of circuits for its use.

This development was based on an analysis of tuner requirements. The requirements for good tuner performance are determined by signal level, the type of antenna, the length of the transmission line, and the ambient interference levels. Therefore, if a television receiver is to work under a large variety of conditions, each of the following factors of tuner performance is highly significant: signal-to-noise ratio, selectivity and band-pass characteristics, voltage gain, amount of oscillator radiation, amount of antenna mismatch, and degree of cross-modulation in the radio-frequency tube, and mixer tube. None of the tubes measured in the previously mentioned investigation permit tuner operation that is adequate for all of the above factors. Some, as for

* Decimal Classification: R583.5.

¹ R. M. Cohen, "Radio Frequency Performance of Some Receiving Tubes in Television Circuits", *RCA Review*, Vol. IX, No. 1, March, 1948.

example the 6J6 and 6J4 triodes, generate little noise but are unstable in neutralized circuits, or have objectionable antenna termination characteristics in grounded-grid operation. The pentodes, for example the 6AG5 and 6AU6, generate considerably more noise, but do not require neutralization and are more stable in tuned-input circuits. Thus improvement may be sought either with triode or pentode operation; a tube or tube and circuit combination which has the advantages of both is the desired objective.

TUNER REQUIREMENTS AND TUBE DESIGN

In considering the relationship of television tuner performance to tube design, the need for high sensitivity, i.e., low noise figure, dictates the use of a triode design having high transconductance, low input loading, low input and output capacitances, and low values of lead inductance.^{2,3} Furthermore, for proper antenna termination the tube should have an input impedance that does not change with variation of the gain-control bias voltage which must be applied to the radio-frequency amplifier stage to avoid overloading with strong signals. To reduce cross-modulation in the radio-frequency amplifier tube, an extended cutoff characteristic is desirable. Unfortunately, this characteristic conflicts with the sharp-cutoff grid design desired for low input loading. The oscillator radiation attributable to the radio-frequency amplifier tube is a function of the capacitance from the radio-frequency amplifier output terminals to the antenna terminals, and of the circuit impedance at these terminals. The low-noise features of triodes have been recognized generally, but stability difficulties and other problems associated with the use of triode tubes in the conventional circuits have limited their extensive application in television tuners. Consequently, pentodes have been used in the radio-frequency stages in most receivers despite their higher noise. The development of the 6BQ7 and its associated circuits offers the possibility of a change in this situation.

The following discussion reviews various conventional triode circuits, outlines the features of the new circuits, and gives their advantages.

² B. J. Thompson, D. O. North and W. A. Harris, "Fluctuations in Space-Charge-Limited Currents at Moderately High Frequencies", *RCA Review*, Vol. VI, No. 1, pp. 114-124, July, 1941.

³ D. O. North and W. R. Ferris, "Fluctuations Induced in Vacuum Tube-Grids at High Frequencies", *Proc. I.R.E.*, Vol. 29, No. 2, pp. 49-50, February, 1941.

GROUNDED-CATHODE AND GROUNDED-GRID CIRCUITS

Figures 1a and 1b show two popular radio-frequency amplifier circuits for triode tubes. The grounded-cathode circuit has the serious disadvantage of requiring a neutralization adjustment which is rather critical and unstable when a tuned input circuit is used. The grounded-grid circuit,⁴ while it does not require neutralization, has a very low input impedance which varies inversely with transconductance. This variation makes it impossible to maintain correct antenna termination when gain-control voltage is applied to the radio-frequency stage. Also it is very difficult to produce the low-inductance input circuit required for good selectivity. It is necessary to provide gain control in the radio-frequency amplifier stage to avoid overloading the intermediate-frequency amplifier when strong signals are present. Variation in receiver input impedance with bias, experienced with grounded-grid

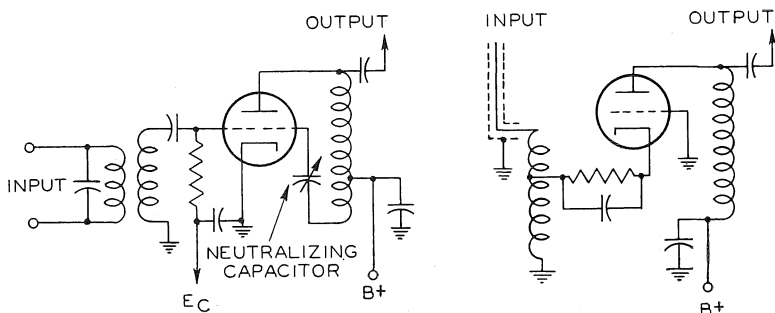

Fig. 1a—Grounded-cathode circuit. Fig. 1b—Grounded-grid circuit.

operation, causes improper antenna termination and resultant reflections which impair definition and may cause ghosts. These facts, plus the lack of a moderate-cost tube suitable for grounded-grid operation, may account for the rather limited use of the grounded-grid stage in the past.

Television boosters, however, do not require gain-control voltage since they are not used generally with strong input signals, and may, therefore, employ push-pull grounded-grid operation. The 6BQ7 has suitable characteristics for this application and data on push-pull grounded-grid operation will be presented.

INVERTED-AMPLIFIER CIRCUIT

The circuits subsequently discussed in this paper are related to the basic inverted amplifier circuit, which is many years old. Figure 1c

⁴ E. F. W. Alexanderson, U. S. Patent No. 1896534, filed May 13, 1927.

shows this circuit, a modification of Alexanderson's grounded-grid-amplifier circuit. This modification was described by C. E. Strong, used commercially and known in pre-war days as the inverted amplifier.⁵ The circuit shown is an improvement of the earlier "Inverted Ultra Audion Amplifier"⁶ of his associate Romander. Whereas Romander proposed eliminating all neutralization, Strong recognized the necessity for neutralization in both the driver stage and the grounded-grid amplifier, and discussed the various types of neutralization such as shunt inductance⁷ and capacitance bridge methods. Strong worked with frequencies of about 20 megacycles in a transmitter, but recognized the utility of the amplifier for "higher frequencies as required for television and other purposes." He predicted its usefulness for low-power work at frequencies exceeding 300 megacycles.

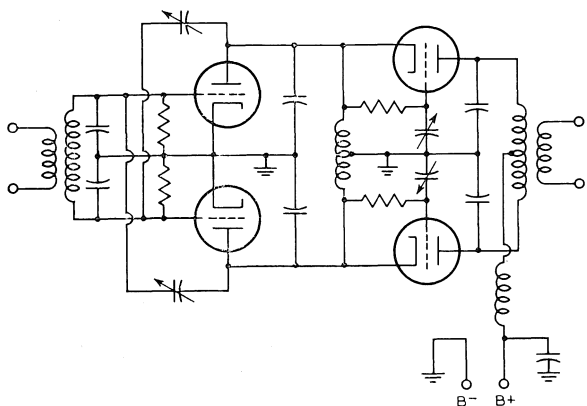

Fig. 1c — Inverted amplifier, push-pull grounded-cathode stages driving push-pull grounded-grid stages.

(TOTAL VOLTAGE FOR BOTH TUBES)

"CASCODE" CIRCUITS

Figure 2 is a "cascode" amplifier described and analyzed by Wallman and his associates and used in their article in a low-noise first intermediate-frequency stage.^{8,9} This circuit arrangement combines the desirable features of a pentode, namely low output-to-input admittance and high input impedance, and the low noise quality of a triode. However, the circuit appears to have serious limitations when used in other than intermediate-frequency amplifiers or other single-

⁵ C. E. Strong, "The Inverted Amplifier", *Electronics*, Vol. 13, No. 7, pp. 14-16, 55, July, 1940; and U. S. Patent 2241892, filed 1937.

⁶ H. Romander, "The Inverted Ultra Audion Amplifier", *QST*, Vol. XVII, No. 9, p. 14, September, 1933.

⁷ Nichols, U. S. Patent 1325879, December 23, 1919.

⁸ F. V. Hunt and R. W. Hickman, "On Electronic Voltage Stabilizers", *Rev. Sci. Instr.*, Vol. 10, p. 16, January, 1939.

⁹ H. Wallman, A. B. Macnee and C. P. Gadsden, "A Low-Noise Amplifier", *Proc. I.R.E.*, Vol. 36, No. 6, pp. 700-708, June, 1948.

frequency amplifiers, because neutralization of the input stage is required for optimum results. This neutralization is not extremely critical at any one frequency and can be accomplished with a tuning coil which is effectively in parallel with the grid-plate capacitance of the first unit. The neutralization coil also serves as a radio-frequency choke returning the cathode of the second unit to ground, thus eliminating the cathode choke otherwise required. This circuit, while well suited for intermediate-frequency amplifier use, is extremely difficult to apply to a multi-channel tuner because the neutralization is frequency-selective, and requires individual coil switching for each channel. Attempts to use this circuit without neutralization have been unsuccessful, except at the lower-frequency channels, because the degenerative feedback increases with frequency. The capacitance to ground from the plate of the input triode and from the cathode of the output triode, plus the distributed capacitance to ground of their connecting leads, also causes degeneration in the higher-frequency chan-

Fig. 2—Cascode circuit.

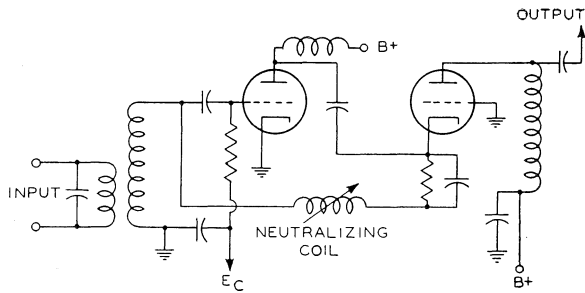

nels where the value of this capacitive reactance approaches the input impedance of the grounded-grid-section. This input impedance is approximately the reciprocal of the transconductance and is in the order of 200 ohms in a tube having a transconductance of 5000 micromhos. A distributed capacitance of only 2 micromicrofarads, because it has a reactance of only 400 ohms at 200 megacycles, appreciably reduces the input impedance of the grounded-grid unit. This effect reduces the gain, causes degeneration due to the capacitive phase angle, and allows the noise of the output unit to contribute to that produced by the input unit, impairing the noise figure.

DRIVEN-GROUNDED-GRID CIRCUIT

Figure 3 is one of the new circuits developed for the 6BQ7 which, for identification purposes, is called the driven-grounded-grid circuit,⁵ although the term is also descriptive of the inverted amplifier and cascode circuits. Note that neutralization is accomplished by means of

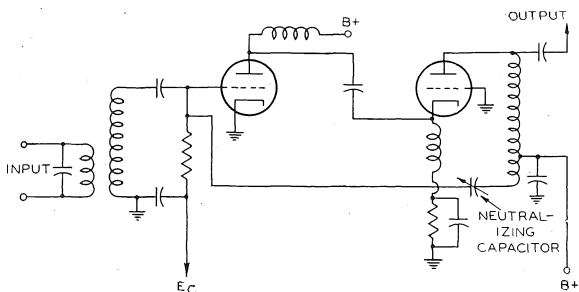

Fig. 3—Driven-grounded-grid circuit.

a bridge circuit commonly employed with single triode amplifiers. This method of neutralization has the distinct advantage of being relatively independent of frequency, provided the connecting leads in series with the neutralization capacitor are short. This circuit requires less involved switching than in the cascode circuit, but requires one more switch contact than a pentode circuit.

DIRECT-COUPLED DRIVEN-GROUNDED-GRID CIRCUIT

Figure 4 is another version of the driven-grounded-grid circuit in which the plate of the input triode is directly coupled to the cathode of the output triode. Neutralization is accomplished in the same manner as previously described. This circuit has the advantage that several components are eliminated from the coupling network between the two units; consequently, the distributed capacitance to ground is reduced and the gain at the higher channels is increased. Another important advantage is that application of bias to the input triode causes the voltage between plate and cathode to increase, extending the cutoff of the tube. This extension reduces cross-modulation, without the use of a remote-cutoff tube. Such a tube would adversely affect the signal-to-noise ratio, either by increasing input loading or by reducing transconductance. Because of lower distributed capacitance between the plate circuit of the input triode and ground, this amplifier

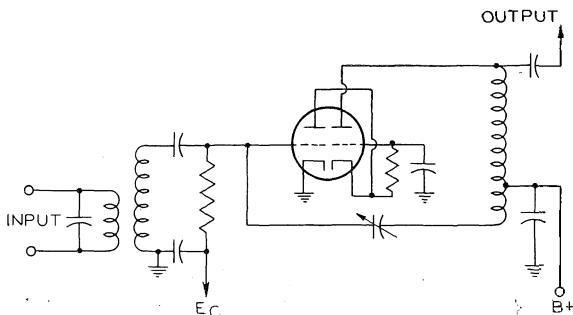

Fig. 4—Direct-coupled driven-grounded-grid circuit.

can give fairly satisfactory results on the low channels without neutralization. It is interesting to note that the number of components in this circuit equals the number required for a conventional pentode amplifier, the grid resistor and bypass capacitor in the grounded-grid triode circuit being equivalent to the screen resistor and capacitor of the pentode circuit.

The foregoing driven-grounded-grid circuits have an input impedance and an admittance from output to input terminals which are dependent to a large extent on certain characteristics of the tubes employed. The 6BQ7 is primarily designed to provide the characteristics needed for good performance in the various driven-grounded-grid circuits. The following detailed description of the 6BQ7 correlates its design features and electrical characteristics with the specific requirements of the driven-grounded-grid circuits.

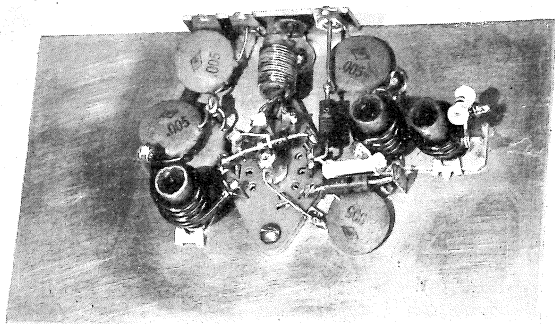

Fig. 5—Layout for direct-coupled driven-grounded-grid circuit using 6BQ7.

CHARACTERISTICS OF THE 6BQ7

Unit one of the 6BQ7 has the plate, grid, and cathode connected to pins 6, 7, and 8 respectively; unit two, which is electrically identical with unit one, has these elements connected to pins 1, 2, and 3 respectively. It is recommended that unit one be used for the input section and unit two for the output grounded-grid section. This connection permits the use of shorter leads and consequently results in less capacitance between the plate and cathode leads of the output section. The shield between the sections aids in preventing excessive coupling between the units. Figure 5 indicates how the selected basing arrangement simplifies wiring and layout.

Table I indicates important 6BQ7 electrical characteristics and ratings. The two units are identical so that the tube can be used not only in the cascode and driven-grounded-grid circuits, but also in push-pull grounded-grid amplifiers, high-frequency counter circuits, and other applications. Fortunately, it is possible to make the tube units

identical without any compromise in grounded-grid circuit performance. The more versatile arrangement should result in higher-volume production and reduced cost. The transconductance value of 6000 micromhos obtained at a plate current of only 9 milliamperes results in high gain and a reduction of equivalent noise resistance. The use of fine grid laterals and close spacing between grid and cathode accounts for this unusually high ratio of transconductance to plate current. The shield used in the 6BQ7 is provided by a shaped grid connector which effectively reduces the plate-cathode capacitance to an average value of 0.135 micromicrofarads without increasing the other critical capacitances. This method of shielding permits either triode to be used for grounded-grid or grounded-cathode operation.

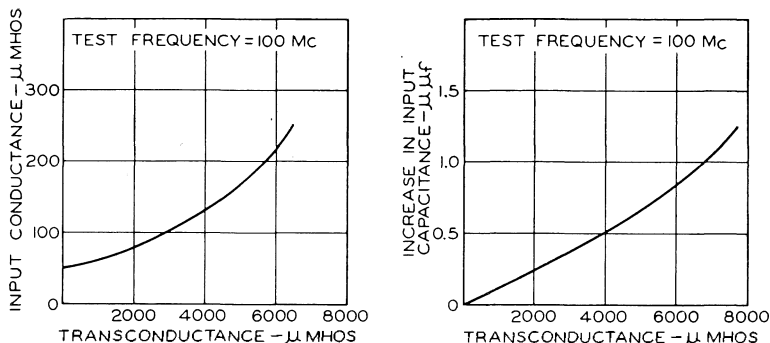

Fig. 6—Variation of input conductance and input capacitance with transconductance in 6BQ7.

Figure 6 gives the input admittance characteristics of the 6BQ7.¹⁰ Because induced grid noise increases with input conductance when high-impedance input circuits are used, low values of input conductance are desirable. The theoretical noise figure for the 6BQ7 obtained by the methods given by Herold¹¹ and Harris¹² is 3.1 decibels at 70 megacycles and 8.6 decibels at 200 megacycles, if it is assumed that the input circuit is impedance-matched, has a 6-megacycle bandwidth and does not benefit from coherence between plate and grid noise. The minimum theoretical noise factors of the 6BQ7 at these frequencies are 3 decibels and 6.4 decibels, respectively.

¹⁰ Taken on admittance meter described in *RCA Application Note AN-118*, April 15, 1947.

¹¹ E. W. Herold, "An Analysis of the Signal-to-Noise Ratio of Ultra-High-Frequency Receivers", *RCA Review*, Vol. VI, No. 3, pp. 302-331, January, 1942.

¹² W. A. Harris, "Some Notes on Noise Theory and its Application to Input Circuit Design", *RCA Review*, Vol. IX, No. 3, pp. 406-418, September, 1948.

In addition to influencing the generation of noise, too high an input conductance may limit the voltage gain from the antenna to the input grid. The input conductance of the 6BQ7 is only 200 micromhos at 100 megacycles and 800 micromhos at 200 megacycles. This latter value, equivalent to an input resistance of 1250 ohms, permits an antenna voltage gain of greater than two in the high-frequency channels, if a matched-impedance input circuit is used. As shown in Figure 6, the input conductance of the 6BQ7 decreases as bias voltage to the control grid is increased. A damping resistor of 10,000 ohms in shunt with the grid circuit is recommended to prevent excessive changes in bandwidth and input impedance as a result of variations in automatic-gain-control bias. The indicated change of input capacitance with bias is sufficient to cause noticeable detuning of the input circuit. When the tube is operated with an unbypassed cathode resistance of 68 ohms, the change of input capacitance with bias is reduced to a negligible value and the variation in conductance is also reduced. However, the resultant degeneration reduces the effective transconductance to 5150 micromhos or by approximately 14 per cent. This degeneration causes a proportionate reduction in gain but does not affect the noise factor. When the tube is used in the series-connected circuit with no unbypassed cathode resistor, the minimum allowable bias is 1.25 volts. When the bias is varied from 1.25 volts to cutoff, the change in input capacitance is 0.3 micromicrofarads. The resultant detuning will be approximately 1.7 megacycles in a high-impedance input circuit having a total capacitance of 20 micromicrofarads shunting the input coil and tuned to channel thirteen. This value of detuning is lower than that which occurs with other tubes.

Figure 7a gives the plate family of characteristic curves for the 6BQ7. The tube has a sharp-cutoff characteristic which results in low input loading, although the cross-modulation is thereby increased to a degree comparable to that obtained with the pentodes. When the series-connected direct-coupled circuit is used, the overall plate characteristic curve for the two tubes is that shown in Figure 7b. The cutoff is extended by a factor of two, without adverse effect on the input loading.

Because the curve more nearly approaches a square-law characteristic, the theoretical requisite for absence of cross-modulation, this type of interference is greatly reduced. Interference measurements indicate that cross-modulation with the direct-coupled circuit is one-eighth that with the capacitively coupled circuit, an improvement which agrees well with theoretical calculation. Figure 7c shows the transconductance variation with bias voltage for the single triode unit and for the series-connected arrangement.

Finally, it is necessary to consider the effect of the radio-frequency amplifier on oscillator radiation. Oscillator radiation is a function of the capacitance between the output plate and input grid and of the terminal impedances, as shown in Figure 8. Most of the attenuation occurs between the plate and cathode of the grounded-grid unit because of the low value of the parallel combination of the plate-to-cathode and plate-to-plate capacitances, and also because of the low impedance between the cathode and ground. The plate-to-plate capacitance, C_2 , is reduced to a very low value by the shield between the units. The total voltage attenuation is calculated to be 35.6 decibels at 200 megacycles, assuming the plate-to-grid capacitance of the input unit is not neutralized.

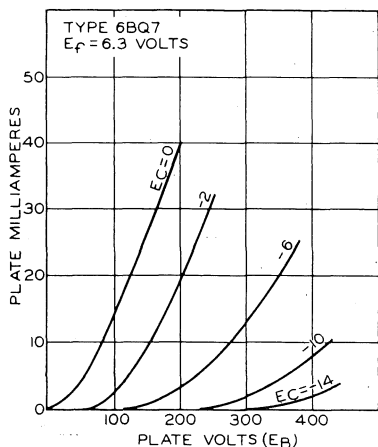

Fig. 7a—Average plate characteristics of each unit.

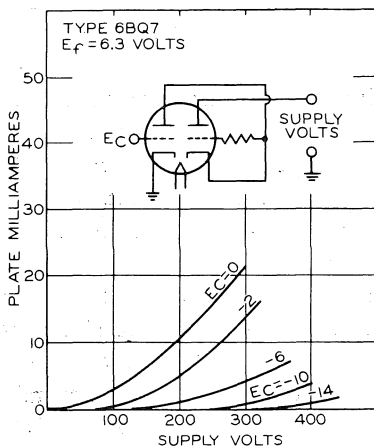

Fig. 7b—Average plate characteristics, series-connected.

This attenuation is slightly larger than that for pentode circuits, and is several times larger than that of the grounded-grid arrangement. Measurements of the actual oscillator radiation from the neutralized circuit indicate that the oscillator radiation is not appreciably affected by the neutralization. Operation without neutralization is considered later when the practical problems involved in applying the circuits to a television receiver are discussed.

PERFORMANCE MEASUREMENTS

There are no standard methods of measuring the performance of a tube in tuner circuits. It is possible to obtain a tuner having a pentode radio-frequency stage, measure the performance of the tuner, replace

the radio-frequency stage with the 6BQ7 in suitable circuits, and repeat the measurements. However, to compare one circuit arrangement with another would necessitate rebuilding the radio-frequency stage of the tuner for each circuit tried, a laborious and time-consuming process. The results obtained would be dependent to some extent on

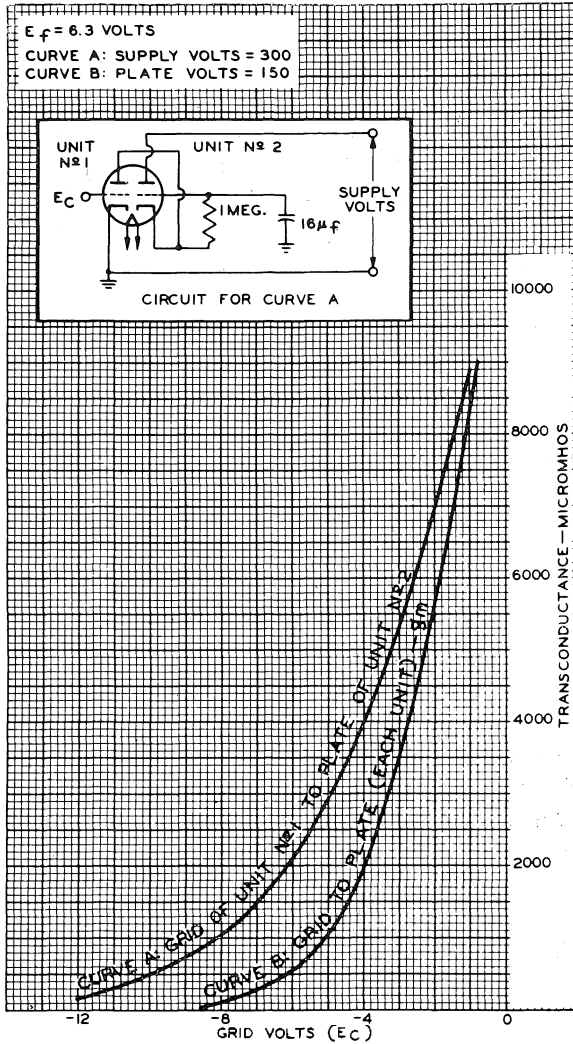
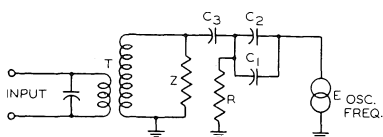

Fig. 7c — Variation of transconductance with bias voltage for single 6BQ7 unit and for series-connected arrangement.

the particular mechanical arrangement of the tuner selected and would not necessarily be indicative of what could be expected from other types of tuners. The switching mechanism introduces additional variables in the form of inductance and shunt capacitances which limit the performance of the system. To avoid speculative valuations of



C_1 = PLATE-TO-CATHODE CAPACITANCE OF UNIT 2
 C_2 = PLATE-TO-PLATE CAPACITANCE BETWEEN UNITS
 C_3 = GRID-TO-PLATE CAPACITANCE OF UNIT 1
 R = INPUT ADMITTANCE OF GROUNDED-GRID UNIT
 Z = IMPEDANCE OF INPUT CIRCUIT TO OSC. FREQ.
 T = TRANSFORMATION RATIO

Fig. 8—Equivalent circuit for oscillator radiation of driven-grounded-grid circuit.

installed in a turret-type tuner and the two sets of data were compared in order to evaluate the relative efficiency of the tuning unit alone. The performance is believed to be typical of what can be expected from turret-type tuners.

Figure 9 shows the block diagram of the test setup employed in measuring performance. Data on each unit are obtained on channels four, eleven, and thirteen. Noise measurements are made using a square-law vacuum-tube voltmeter and a high-gain intermediate-frequency amplifier having a bandwidth of 4.5 megacycles.

The signal generator has a balanced output with a matching resistor in each conductor to provide a total balanced impedance of 300 ohms. A noise generator incorporating an emission-limited diode is used to check the signal-generator calibration. The noise information is presented as a noise figure which indicates the ratio of the noise produced by the receiver to that of an ideal system having as a source of noise only the 300-ohm antenna resistance. The noise produced by the receiver is measured by reducing the output of the signal generator to zero and noting the output on the meter. This output is proportional to the square of the amplified noise voltage and thus is a function of noise power. An unmodulated carrier is then applied to the input terminals by the generator and the value of the input signal is adjusted to double the noise reading at the output. The receiver noise, referred to the input terminals, is equal to the signal-generator input voltage; the ratio of this voltage to that calculated to be produced by

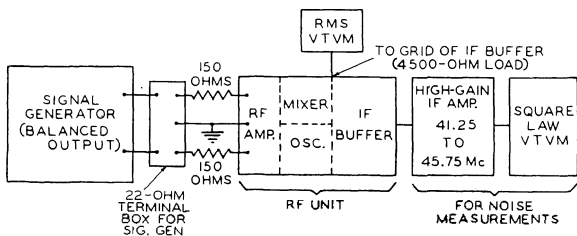

Fig. 9—Block diagram of test set-up.

the 300-ohm antenna resistance is expressed in decibel relationship as the noise figure.

Gain figures are obtained in the following manner. The 6X8, a new triode-pentode, is used as an oscillator-mixer and its output is measured across a 4500-ohm load at the grid of the first intermediate-frequency amplifier stage. The voltage output divided by the value of signal input voltage as indicated on the signal generator is the overall gain from the antenna to the first amplifier, including the mixer gain which is maintained constant for the various circuits tested. This method avoids the uncertainty involved in direct measurement of a 200-megacycle signal. The frequency of the mixer output voltage is 45 megacycles, at which frequency it is possible to measure voltages with good accuracy. Values for the gain of the radio-frequency stage alone are closely equal to the overall gain divided by the mixer gain, which is approximately five.

Antenna termination is measured by determining the standing-wave ratio of the transmission line by means of a small single-turn loop tuned to the signal frequency and loosely coupled to the line. The energy picked up by the loop is applied to the input of a sensitive receiver having a calibrated diode detector at the intermediate-frequency output. The values shown are voltage standing-wave ratios measured along a 75-foot 300-ohm twin-lead line having the antenna end connected to the signal generator. Placing a 5000-ohm resistor in series with each lead effectively makes the antenna end of the line an open circuit. When the receiver properly terminates the transmission line, there are no standing waves on the line.

Measurements of the performance of the 6BQ7 in the push-pull grounded-grid circuit, the driven grounded-grid circuit, and the directly coupled driven grounded-grid circuit are presented in Table II and are compared with measurements on other tube types in Table III. No data were taken on the neutralized triode and cascode amplifiers because neutralization difficulties make these circuits unsuitable for this application.

Figure 10 shows the push-pull grounded-grid circuit. Bifilar chokes are used in the heater circuit to prevent variations in heater-cathode capacitance from affecting the tuning of the input circuit. For optimum performance, the input circuit should match the antenna to the low input impedance of the tube, and the bandwidth of the circuit should not exceed six megacycles. Since the input circuit is heavily loaded by the low input resistance of the tube, the circuit must have an extremely low L-to-C ratio in order to meet this bandwidth requirement. The requirement cannot quite be met on the higher channels.

For example, at 213 megacycles (the center of the highest very-high-frequency channel), the capacitance needed across a parallel tuned circuit to obtain the required selectivity is 87 micromicrofarads; the inductance required has the unattainably low value of 0.0064 microhenry.

Extreme care must be taken to ground the grid with the shortest practical lead, and wafer sockets of a special design having the contact lug emerging from the edge of the socket between the wafers are recommended. These sockets should also be used in the other circuits which require the grounded-grid connection. No automatic-gain-control bias is applied to the amplifier since the resultant change in input impedance of the tube would be intolerable from an antenna termination standpoint. The performance data for this circuit is shown in Table II. It is probable that the figures shown here for image rejection are somewhat optimistic since it is easier to develop

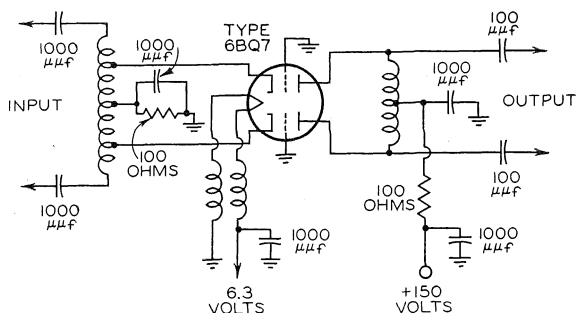

Fig. 10 — Push-pull grounded-grid circuit.

the proper input circuit on the experimental breadboard than it would be in a commercial tuner or preamplifier.

Figure 11 shows the neutralized driven-grounded-grid circuit having conventional capacitance coupling between tube units. On low-frequency channels, optimum performance occurs when the input circuit is double-tuned, the primary is matched to the 300-ohm antenna, and the secondary is operating at the highest impedance attainable without reducing the bandwidth to less than six megacycles. On the high channels, very close coupling is used in the input transformer to reflect a low value of impedance to the secondary winding. The input transformer should be slightly overcoupled, and it is desirable to reduce the capacitive coupling by winding the secondary in a figure-eight configuration or by using electrostatic shielding. One convenient way of obtaining such shielding is to place some high-dielectric-constant ceramic material between the coils with the edge of the ceramic shield grounded, so as to effectively short circuit to ground the capacitance

between the shield and each coil. When the grounded-grid unit is wired, care must be taken to place the leads so that the plate-cathode capacitance is not unduly increased, or the grounded-grid stage will oscillate. Because the heater leads and the plate of the input stage are at the radio-frequency potential of the cathode of the output unit, they must be placed so that coupling to the output plate is avoided. The small capacitor shunting the plate coil couples one side of the coil to the other in order to avoid a parasitic effect. Without this capacitor, the portion of the coil between the tap and the lower end of the coil forms a series circuit with the neutralizing capacitor which absorbs signal energy from the input circuit; furthermore, the lower

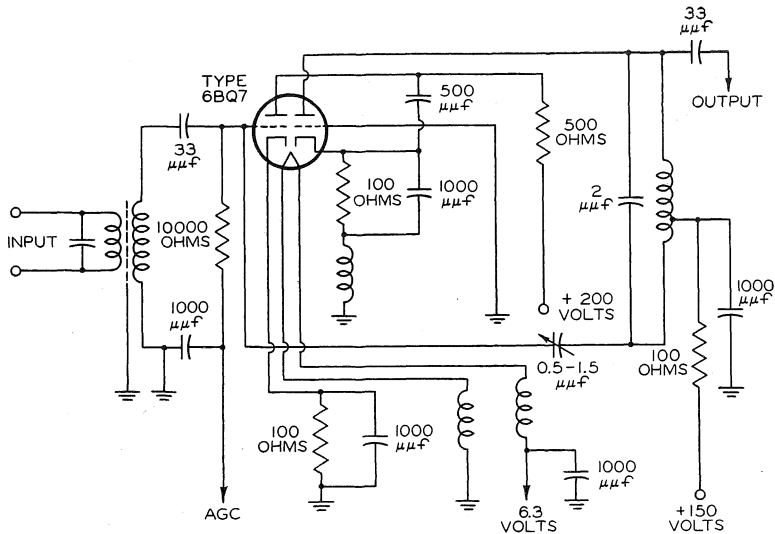

Fig. 11—Driven-grounded-grid circuit.

section of the coil has no effect on the resonant frequency of the output circuit. These effects are due to insufficient coupling between the two sections of the coil. The addition of the tank capacitor proves to be the most practical method of obtaining the necessary coupling.

The neutralization method shown is quite practical when applied to a turret-type tuner, requiring only one additional switch contact and a non-critical adjustment; it is not practical for the conventional switch-type tuner unless an extra switch wafer is provided. When this circuit is not neutralized, serious degeneration results at the higher frequency bands, but operation at the lower frequencies is only slightly impaired.

As a result, the following arrangement appears to be a practical way of operating driven-grounded-grid circuits in the very-high-

frequency tuner application when it is desired to reduce the neutralization cost. The heater chokes are adjusted to be approximately in resonance with the plate-to-ground capacitance of the first unit at a frequency of 200 megacycles. Since the amount of degeneration is a function of the magnitude of the capacitance from plate to ground, tuning out this capacitance eliminates degeneration. The resultant resonance is effective throughout the high-frequency band because the coil is heavily damped by the low and unvarying input impedance of the grounded-grid unit. No neutralization is provided for the low band. Such neutralization improves the noise figure only by one decibel and requires additional circuit complexity which is economically unjustified.

It should be noted that the tuning out of the plate-to-ground capacitance of the input unit mentioned above is not completely realized. The capacitance actually shunting the heater chokes consists of two parallel components: namely, the heater-to-cathode capacitance of the input unit, and the series combination of the heater-to-cathode capacitance of the second unit and the capacitance between the cathode of the second unit and ground. Because the heater-to-cathode capacitance is of the same order of magnitude as the cathode-to-ground capacitance of the output unit, the cathode is effectively tapped down on the resonant circuit. Any attempt to remedy this situation by increasing the heater-to-cathode capacitance is impractical, because such a step causes deterioration of performance on the low channels.

Table II compares the performance of the driven-grounded-grid circuit for the two methods of operation. With the heater-choke arrangement, the noise factor is greatest but only by two decibels in the worst case, on channel six. The standing-wave ratio is satisfactory and is comparable to that of the better pentode circuits. Cross-modulation in the radio-frequency amplifier is comparable to that experienced with the sharp-cutoff type of pentode tubes now used.

Figure 12a shows the direct-coupled driven-grounded-grid circuit which gives the most satisfactory performance of the various circuit arrangements tested. The reduction of distributed wiring capacitance in the coupling circuit results in higher gain and lower noise as shown in Table II. Antenna termination and cross-modulation are improved considerably over the results obtained with the capacitor-coupled circuit. Operation of the series circuit with a minimum bias of -2 volts, which is recommended to minimize variation in input admittance, results in improved termination without impairment of noise figure. The extension of cutoff as the result of the series connection reduces the cross-modulation.

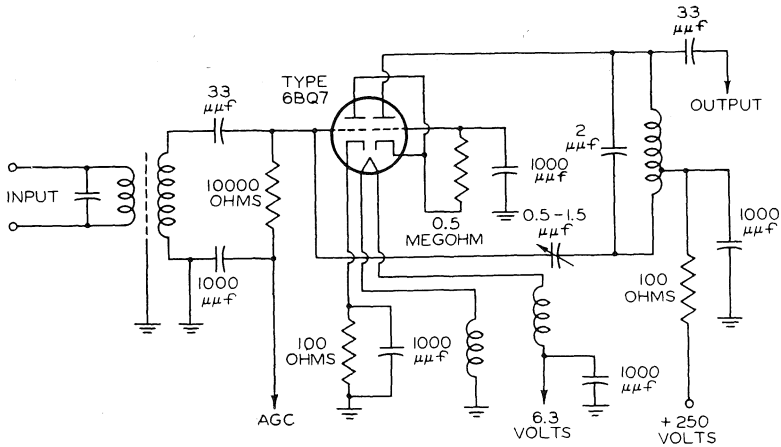

Fig. 12a—Direct-coupled driven-grounded-grid circuit.

Another modification of the driven-grounded-grid circuit¹³ is that shown in Figure 12b. Here, the heater chokes, which are nonresonant at the television frequencies, are used only to reduce undesirable microphonic effects caused by heater-cathode capacitance variations. Coil L_1 and the distributed circuit capacitance C_d between the cathode of the output unit and ground, are series resonant at a frequency of 200 megacycles. This series circuit presents a very low impedance between

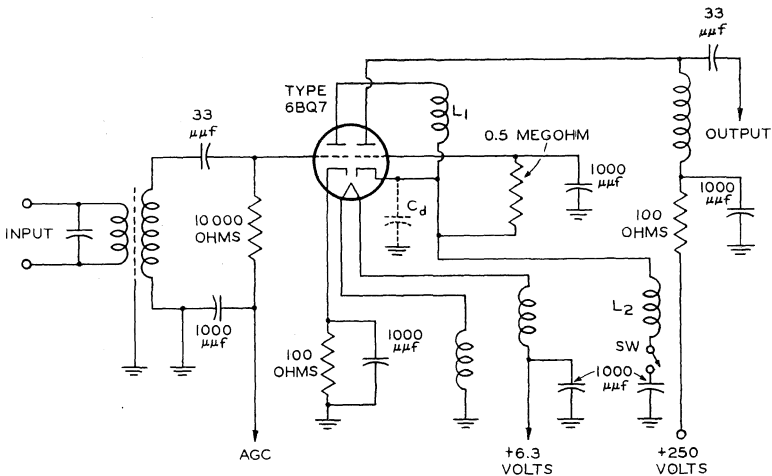

Fig. 12b—Alternate method of utilizing direct-coupled driven-grounded-grid circuit. ($L_1 = 8$ turns 24E, 3/16-inch diameter air core, spaced one diameter. $L_2 = 16$ turns 24E, 3/16-inch diameter air core, spaced one diameter.)

¹³ This circuit was developed by J. C. Achenbach and P. C. Swierczak of Home Instrument Department, RCA Victor Division, Camden, N. J.

the input plate and ground, thereby reducing the radio-frequency voltage on the input plate sufficiently to make conventional neutralization unnecessary. The fact that C_a is shunted by the input impedance of the output unit limits the resonant voltage across C_a to a value which is nearly equal to that applied to the input grid.

The high-channel performance of this circuit equals that obtained with feedback neutralization. Like the previously discussed heater-choke arrangement, this circuit has a sufficiently wide frequency response to permit the use of fixed components. This circuit has the additional advantages of lower cost and greater ease of adjustment.

If better low-channel noise performance is desired in this circuit, an improvement of approximately one-decibel results when a modification of the series-tuned circuit is used. Coil L_2 and blocking capacitor C in series form a parallel circuit with C_a that is resonant at the center of the low-frequency band. For high-band operation, L_2 is switched out at the low-impedance terminal. This coil must be so positioned that the capacitance between it and ground is minimized.

Table III shows noise data taken on other tubes in typical circuits and is included for comparison purposes. The data are obtained with similar testing methods and show the relative merits of the 6BQ7. Only the push-pull neutralized 6J6 affords comparable results, but this circuit is impractical because of difficulties in neutralization.

PRACTICAL RESULTS IN A TURRET TUNER

It was thought desirable to substantiate the encouraging results obtained in the laboratory test set-ups with field tests in commercial-type receivers. The direct-coupled driven-grounded-grid circuit, because it provides the most satisfactory operation, was built into a turret-type television tuner which originally had a 6CB6 pentode stage. The following is a discussion of the problems experienced in installing this improved tuner in a television receiver.

As the sensitivity of the receiver is increased, its susceptibility to interference from other sections of the receiver which radiate energy also increases. The magnetic-deflection system usually generates a multitude of extraneous frequencies which are capable of causing interference at the signal frequency, either by heterodyning with harmonics of the local oscillator, or by cross-modulation. The elimination of radio-frequency interference produced by the deflection system is a subject in itself and will not be discussed other than to mention that additional shielding and supply-voltage filtering were found to be necessary. Another source of interference which will require additional shielding in most receivers is radiation from the second detector, the

harmonics of which couple back to the radio-frequency circuits. In the receiver used, this type of interference was particularly troublesome; it was finally limited to reasonable proportions by extensive shielding of the detector circuit.

The action of the automatic-gain-control system is another important factor in affecting the results obtained in receivers. Too early an application of control voltage to the radio-frequency amplifier reduces its gain, permitting the converter noise to add to the overall noise figure. On the other hand, too great a delay in the application of automatic-gain-control voltage to the radio-frequency stage causes cross-modulation. The correct adjustment is therefore a compromise. The relationship between radio-frequency and intermediate-frequency bias-control voltages must be carefully selected because it has an appreciable effect on overall performance. To take full advantage of the remote cutoff characteristics of the radio-frequency amplifier in the direct-coupled circuit, an amplified automatic-gain-control system appears desirable.

As expected, some degradation in performance is experienced when the tube and circuit are installed in the turret-type tuner. Measurements were made first with the circuit having feedback neutralization, and then with the circuit having resonant heater chokes. Table IV includes data taken before the tuner was converted, thus indicating the degree of improvement directly attributable to the use of the 6BQ7. Field tests were made with the receiver and the results confirmed the laboratory data to a satisfactory degree.

USE OF THE 6BQ7 IN ULTRA-HIGH-FREQUENCY RECEIVERS

Analysis of the ultra-high-frequency tuner problem for a proposed carrier frequency range of approximately 470 to 890 megacycles in a receiver having an intermediate frequency of 43 megacycles and a crystal mixer, reveals that the characteristics of the first intermediate-frequency amplifier tube are important in determining the noise figure. To a close approximation, the noise figure of the intermediate-frequency system, determined by the first intermediate-frequency amplifier stage, added to the noise figure of the radio-frequency system equals the overall noise figure. Unless radio-frequency amplifier tubes are used ahead of the crystal mixer, the signal level at the grid of the first intermediate-frequency tube will be low due to the approximately 9 decibels of attenuation in the crystal mixer stage. An intermediate-frequency preamplifier stage is needed to provide an overall receiver gain on the ultra-high-frequency band equal to that obtained on the

very-high-frequency bands. It is a relatively simple problem to use the 6BQ7 as an intermediate-frequency preamplifier stage at 43 megacycles, either in the cascode circuit or in the driven-grounded-grid circuit. Because of the very low plate-cathode capacitance of the 6BQ7, it is not necessary to neutralize the output section when the circuit wiring is carefully oriented to avoid excessive coupling from plate to cathode. The input section should be neutralized to avoid degeneration and a resultant 2-decibel noise increase. The noise figure is approximately 4.5 decibels in a neutralized circuit operating at a center frequency of 43 megacycles and with a five-megacycle bandwidth. The use of the direct-coupled circuit has advantages with respect to cross-modulation and is recommended when gain-control voltage is to be applied to the intermediate-frequency preamplifier. Figure 13 shows

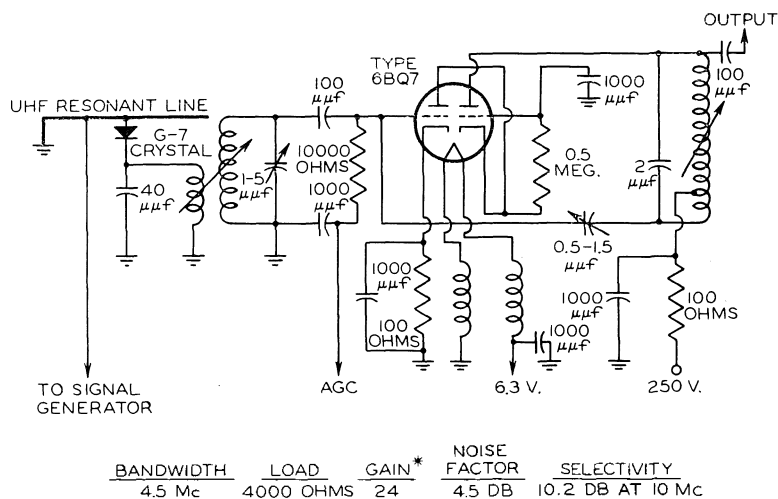

* FROM GRID OF 6BQ7 TO GRID OF FIRST IF AMP.

Fig. 13—Intermediate-preamplifier for ultra-high-frequency applications.

the crystal mixer and the 6BQ7 as the intermediate-frequency preamplifier. The low output impedance of the crystal mixer, in the order of 300 ohms, should be matched to the input circuit of the intermediate-frequency tube which should have as high an impedance as it is practical to develop without reducing the required bandwidth.

If the total input capacitance is 15 micromicrofarads, it should be possible to develop an input impedance of 2100 ohms. The input resistance of the 6BQ7, which at this frequency is approximately 20,000 ohms, is, therefore, not a limiting factor in obtaining the required circuit impedance, but must be considered when the required value of

damping resistance is calculated. It should also be recognized that the input resistance increases rapidly with the application of bias voltage, and it may be necessary to use a lower value of damping resistance to effect a satisfactory compromise. An unbypassed cathode resistance of 68 ohms may also be used to minimize the variation in input admittance.

FURTHER REFERENCES

"Grounded-Grid Amplifiers," by E. E. Spitzer in *RCA Broadcast News*, October 1946, pages 66-69, and in *Electronics*, April 1946, pages 136-142.

"Low Noise Preamplifier," by F. B. Llewellyn in *Electronics*, April 1946, page 97.

"Cathode-Coupled Wide-Band Amplifiers," by G. C. Sziklai and A. C. Schroeder in *Proc. IRE*, October 1945, pages 701-708.

Patents — USP 2460907, Schroeder; 2093078, R. A. Husing (Filed 1934); 1986597, A. Nyman (Filed 1931); 1886386, D. T. Francis (Filed 1928).

ACKNOWLEDGMENT

The author wishes to acknowledge the valuable work contributed by H. J. Prager and J. Johnston in the design of the 6BQ7 and by E. M. Troy in establishing electrical ratings and characteristics.

Table I — RCA 6BQ7 Electrical Characteristics and Tentative Ratings

Direct Interelectrode Capacitances (micromicrofarads)

	Unit 1	Unit 2
Grid to Plate	1.15	1.15
Plate to Cathode	0.15 max.	0.15 max.
Heater to Cathode	2.20	2.30
Input	2.85	4.95*
Output	1.35	2.27*
Plate of Unit 1 to Plate of Unit 2	0.010 max.	
Plate of Unit 2 to Plate & Grid of Unit 1	0.024 max.	

Class A₁ Amplifier

Max. Ratings, Design-Center Values: (each unit)

DC Plate Volts	250 max. volts†
DC Cathode Current	20 max. milliamperes
Plate Dissipation	2.0 max. watts
Peak Heater-Cathode Volts	
Positive	200 max. volts
Negative	200 max. volts†

* Read as grounded-grid amplifier.

† This rating may be as high as 300 volts under cutoff conditions.

Table I — (Continued)

Characteristics (each unit)

Plate Volts	150 volts
Cathode-Bias Resistor	220 ohms
Amplification Factor	35
Transconductance	6000 micromhos
Plate Resistance	5800 ohms
Plate Current	9 milliamperes

Maximum Circuit Values (each unit)

Grid-Circuit Resistance	0.5 max. megohm
-------------------------	-----------------

Typical Operation in Push-Pull Grounded-Grid Circuit

(Values are for each unit)

Plate Volts	150 volts
Grid Volts‡	-2 volts
Plate Current	10 milliamperes
Cathode Resistor (common to both units)	100 ohms

Typical Operation in Driven-Grounded-Grid Circuit with Direct-Coupled Drive. Unit 1 (driver unit) is directly coupled to Unit 2 (driven-grounded-grid amplifier unit).

	Unit 1	Unit 2
Plate-Supply Volts	250	250 volts
Plate Volts	135	115 volts
Grid Volts	-1	- volt
Grid-Resistor	—	0.5 megohm
Plate Current	10	10 milliamperes
Grid Current	0	0 milliamperes
Grid Volts (Approximate) for plate current of 10 microamperes	-14	- volts
Heater-Cathode Volts		
Heater negative with respect to cathode	—	225 volts

‡ Obtained from cathode resistor.

Table II — Tabulation of Circuit Performances with 6BQ7

Circuit	Channel	RF Gain	Overall Gain	Noise Figure (db)	Image Rejection (db)	Standing Wave Ratio	
Push-pull grounded-grid	4	9	45	7	42	less than 1.1 when no AGC is used	
	11	9	45	7	38		
	13	8.5	42	7	35		
Driven-grounded grid	(a) feed-back capacitor	4	15	75	6.8	45	1.15
		11	14	70	7.0	42	1.2
		13	14	70	7.2	42	1.2
	(b) resonant heater choke	4	14	70	7.1	42	1.15
		11	12	60	8.1	42	1.2
		13	12.5	62.5	7.9	41	1.2
Direct-coupled, driven-grounded-grid	4	17	85	6.0	45	1.15	
	11	16	80	6.0	42	1.2	
	13	16	80	6.0	42	1.2	

Table III — Comparison of 6BQ7 with Other Tubes in Typical Circuits

Tube Type	Circuit	Measured Gain		Image Rejection (db)		Noise Figure (db)	
		Channel No.	Channel No.	Channel No.	Channel No.	Channel No.	Channel No.
6J6	Push-pull neutralized grounded-cathode with untuned input	4	11	4	11	4	11
		60	60	35	35	13	13
6J6	As above with tuned input and neutralized	120	120	45	45	6	6
6AU6	Grid-cathode input input circuit untuned	30	25	35	30	20	20
6J6	Grounded-grid RF amplifier and 6J6 cathode-coupled mixer	15	15	40	40	8	9
6J4	Grounded-grid RF amplifier and 6J6 cathode-coupled mixer	30	30	40	40	6	6
6BQ7	Direct-coupled driven grounded-grid circuit	85	80	45	42	6	6

Table IV — Performance Data of Turret-Type Tuner

RF Amplifier	Channel	RF Gain	Noise Figure (db)	Image Rejection (db)	Standing Wave Ratio
Type 6CB6	2	14	7.2	80	1.6
	6	11	11.0	70	1.2
	7	9	13.2	70	1.3
	13	8	14.0	70	1.35
Type 6BQ7 in direct-coupled circuit having resonant heater chokes	2	14	7.1	80	1.25
	6	12	7.8	70	1.2
	7	12	8.1	70	1.25
	13	12.5	8.9	70	1.25
Type 6BQ7 in direct-coupled circuit using feedback neutralization	2	15.5	6.8	80	1.25
	6	15.0	7.2	70	1.25
	7	14.0	8.1	70	1.25
	13	14.0	8.5	70	1.25